

Sulion

Alma 100 / 132

Ref.: 2241289 / 2241302 / 2241296



Video de instalación / Installation video / Vidéo d'installation / Video de instalação / Installationsvideo / Video dell'installazione / Βίντεο εγκατάστασης

 **SAT**

sulion.es 
+34 621262721 
sat@sulion.es 

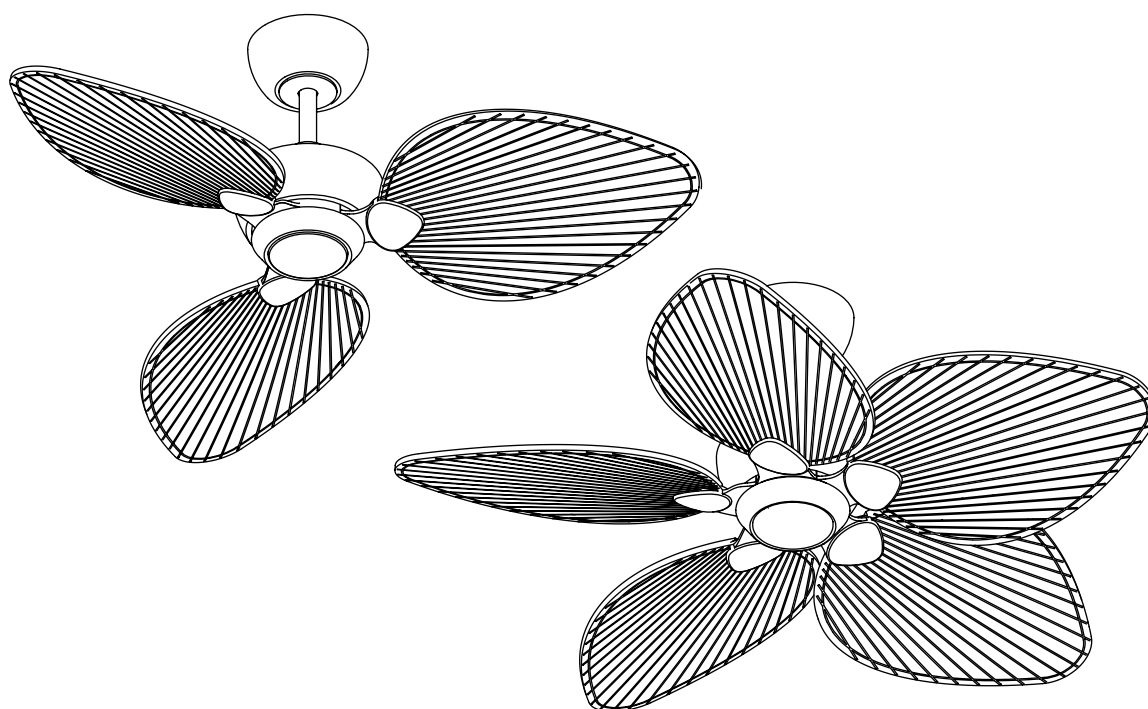

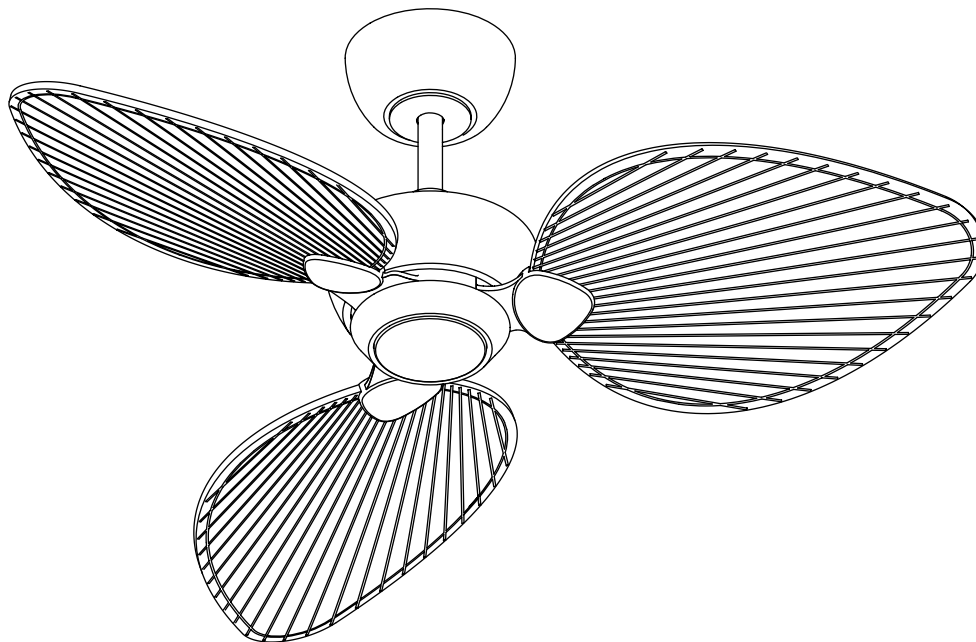



3 Blades



220-240V
~AC
A1

f
50/60 Hz
A2

A3



IP 44
A7



-20 ↔ 50°C
A9



15°
A10

<0,5W
A12

IEC
60879:
2019
D9

E2

433.92
MHz
E4



10 dBm
E5

Alma S ₁₀₀

kg
5,8 kg
A11

Alma L ₁₃₂

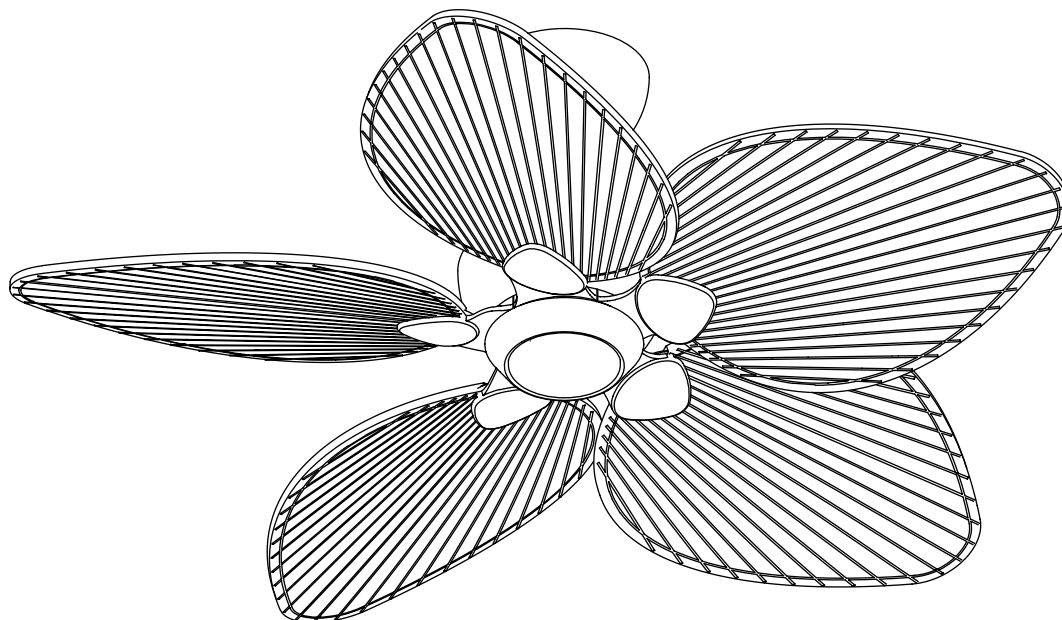
kg
6,8 kg
A11





5 Blades



220-240V
~AC
A1

f
50/60 Hz
A2

A3



IP 44
A7



-20 ↔ 50°C
A9



15°
A10

<0,5W
A12

IEC
60879:
2019
D9

E2

433.92
MHz
E4

10 dBm
E5

Alma S 100

kg

6,8 kg
A11

Alma L 132

kg

8,4 kg
A11

Alma S 100

3 and 5 Blades



32,5
kWh/1000h
A13



6,3
m³/min/W
D7



2,8 m/s
D8



n°
D1



W
D2



RPM
D3



m³/min
D4



m³/h
D5



dB
D6

1	4	85	58	3492	29
2	6	115	79	4724	32
3	7	130	89	5341	36
4	8	145	99	5957	39
5	10	160	110	6573	42
6	12	177	121	7271	46
7	15	195	134	8011	49
8	20	215	147	8833	51
9	23	228	156	9367	53
10	26	240	164	9860	55

Alma L 132



31,5
kWh/1000h
A13



6,55
m³/min/W
D7



2,8 m/s
D8



n°
D1



W
D2



RPM
D3



m³/min
D4



m³/h
D5



dB
D6

1	1	60	92	5533	32
2	2	75	115	6909	36
3	4	87	134	8009	38
4	5	97	149	8926	40
5	8	113	173	10393	43
6	11	126	193	11585	46
7	15	137	210	12594	49
8	18	145	222	13328	51
9	20	150	240	14386	53
10	25	160	255	15304	54















Light Kit

● NL

Sin luz / No light / Sans lumière / Sem luz / Ohne Licht / Senza luce / Χωρίς φως















○ GL

Luz estándar / Generic light / Lumière standard / Luz padrão / Standardlicht / Luce standard / Φως στάνταρ

 1225 lm B1	 6,5 W B2	 C B3	 CCT 2700 K 5000 K B6	 360° B7	 120° B8	 CRI 80 B9	 30.000 h B10
 10.000 B11	 B12	 B15	 B18	 B20	 kg 0,05 kg A11		

● CL

Luz confort / Comfort light / Lumière confort / Luz conforto / Komfortlicht / Luce confort / Φως άνεσης

 1000 lm B1	 6 W B2	 B B3	 CCT 2700 K 5000 K B6	 360° B7	 50° B8	 CRI 90 B9	 30.000 h B10
 10.000 B11	 B12	 B15	 B18	 B20	 kg 0,3 kg A11		

Herramientas requeridas y componentes / Required tools and components / Outils et composants requis / Ferramentas e componentes necessários / Erforderliche Werkzeuge und Komponenten / Strumenti necessari e componenti / Απαιτούμενα εργαλεία και εξαρτήματα

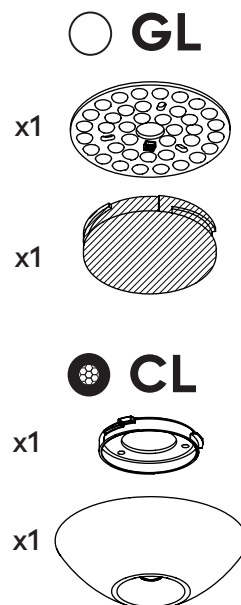
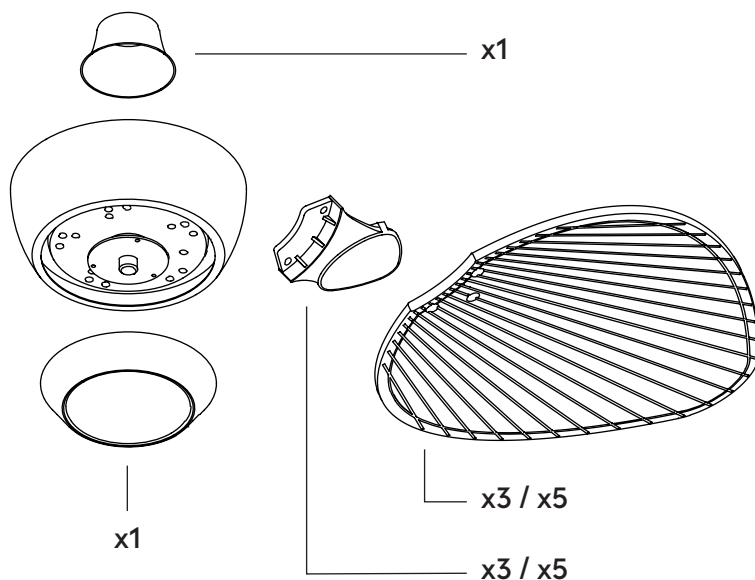
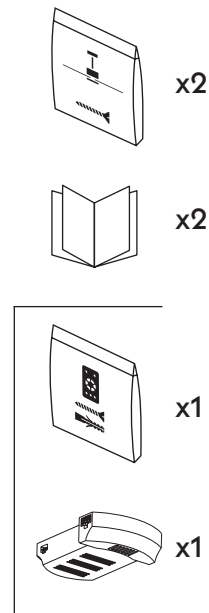
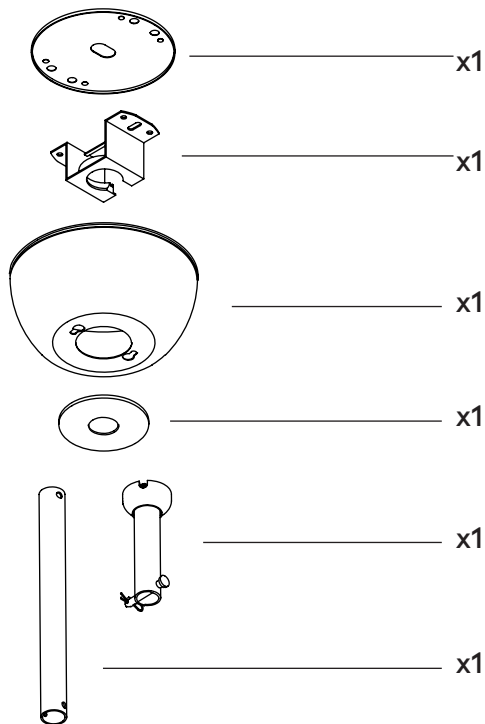

ES Solución de incidencias / FAQ. Preguntas frecuentes / Control de dos o más ventiladores con un único control remoto
EN Troubleshooting / FAQ. Frequently asked questions / Control two or more fans with a single remote control
FR Dépannage / FAQ. Questions fréquemment posées / Contrôle de deux ou plusieurs ventilateurs avec une seule télécommande

PT Solução de problemas / FAQ. Perguntas frequentes / Controlo de dois ou mais ventiladores com um único comando à distância
DE Fehlerbehebung / FAQ. Häufig gestellte Fragen / Steuerung von zwei oder mehr Ventilatoren mit einer einzigen Fernbedienung
IT Risoluzione dei problemi / FAQ. Domande frequenti / Controllo di due o più ventilatori con un unico telecomando
EL Επίλυση προβλημάτων / FAQ. Συχνές ερωτήσεις / Ρύθμιση δυο ή περισσότερων ανεμιστήρων με ένα τηλεχειριστήριο

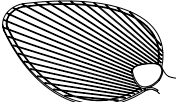
x3 

1 _____

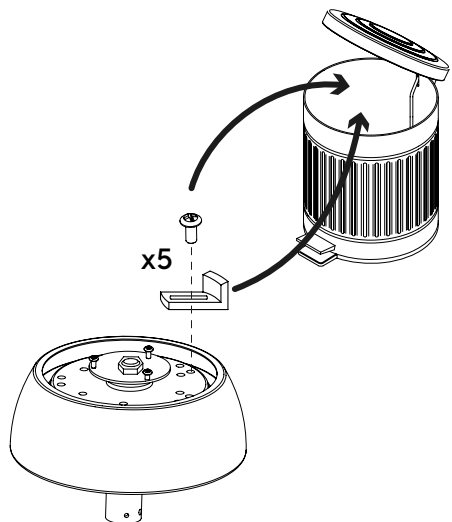

2 _____

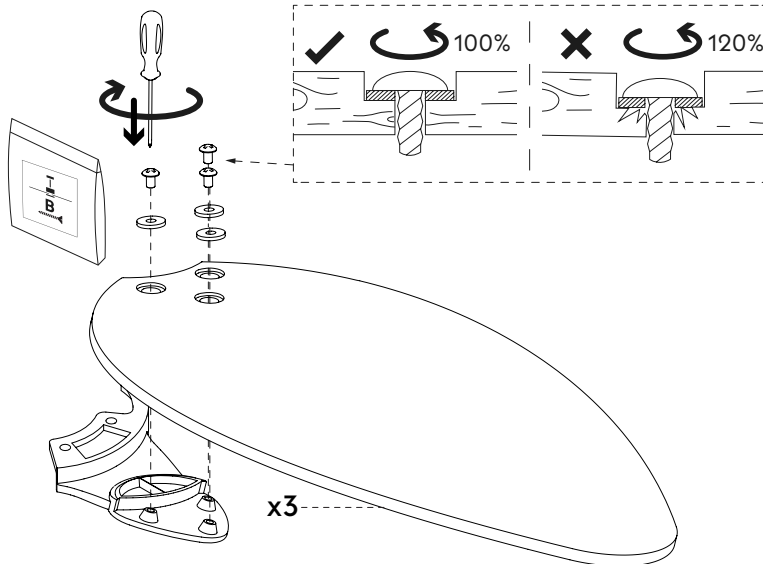

3 _____

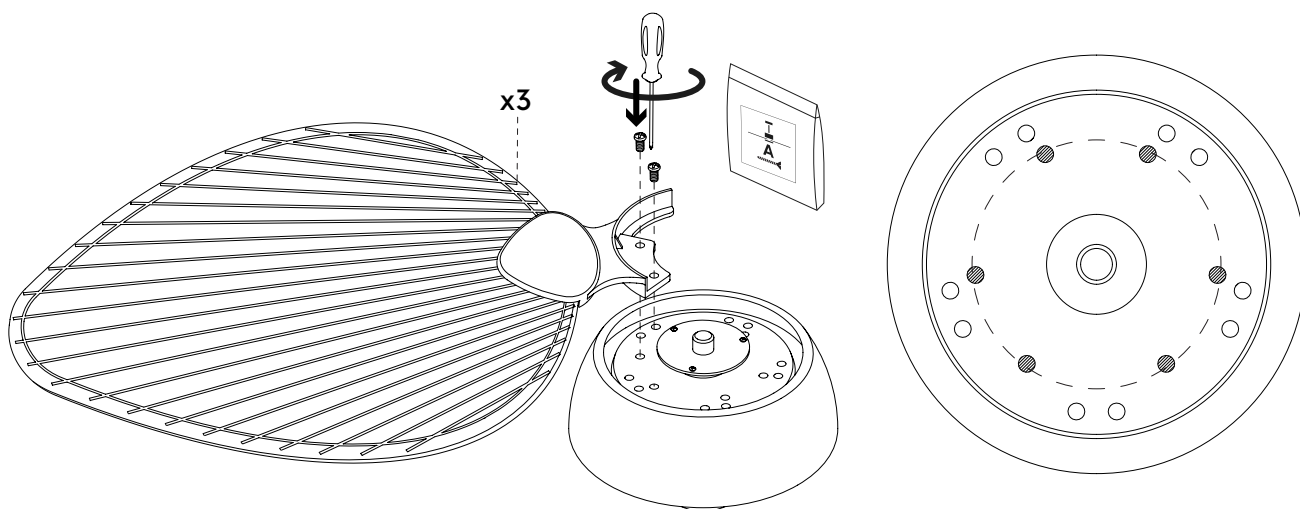

4 _____

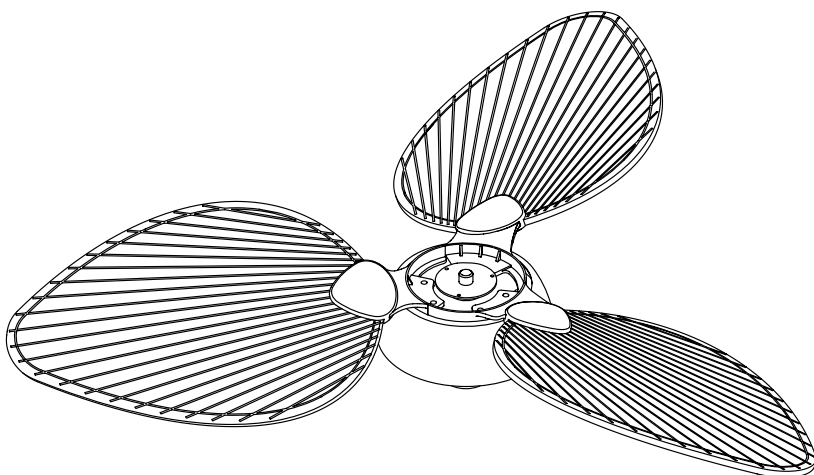

x5 

1

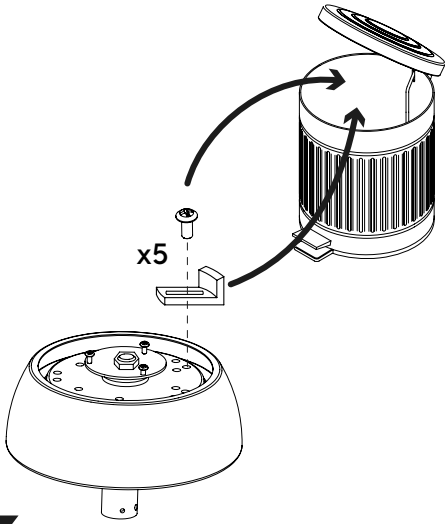

2

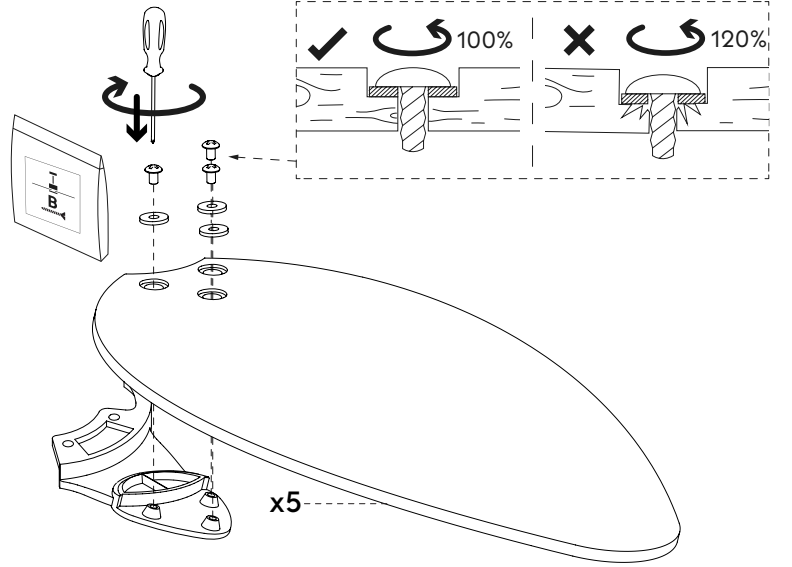

3

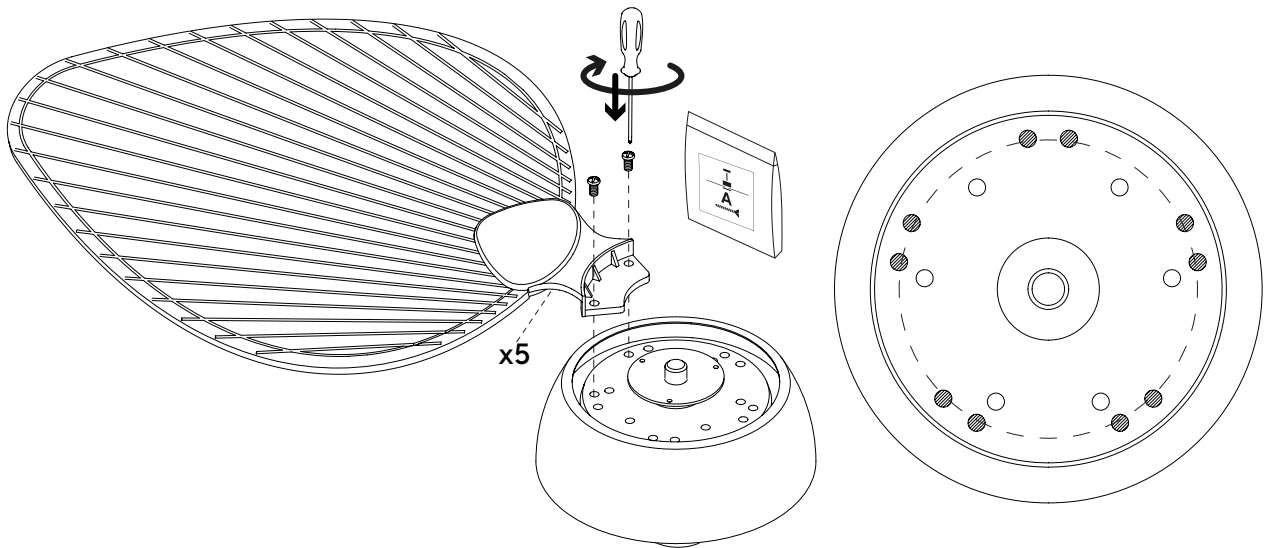

4

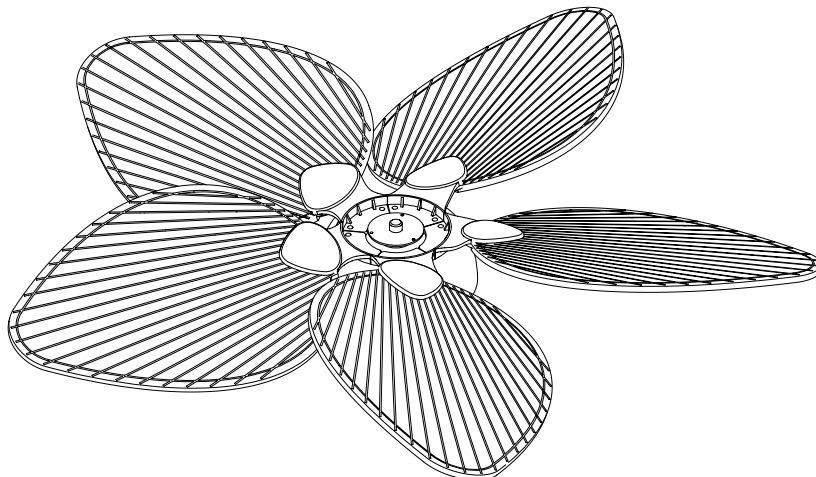

● NL
No light

1

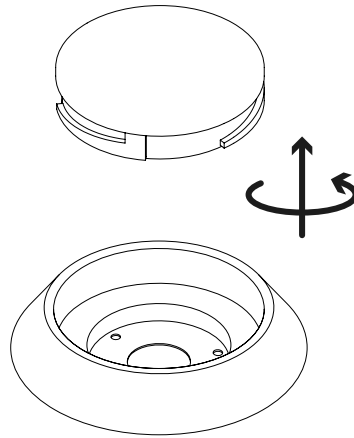

2

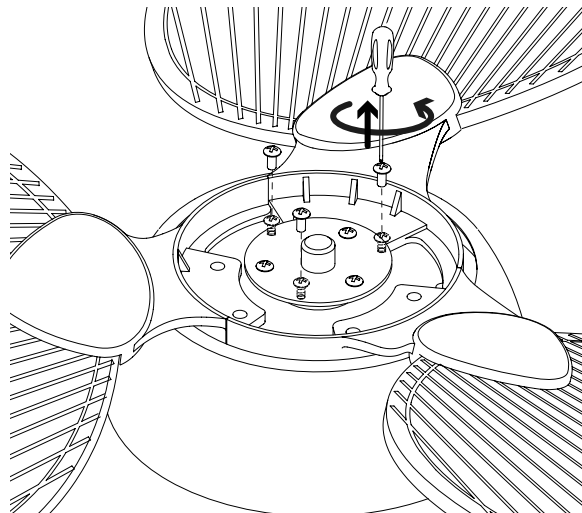

3

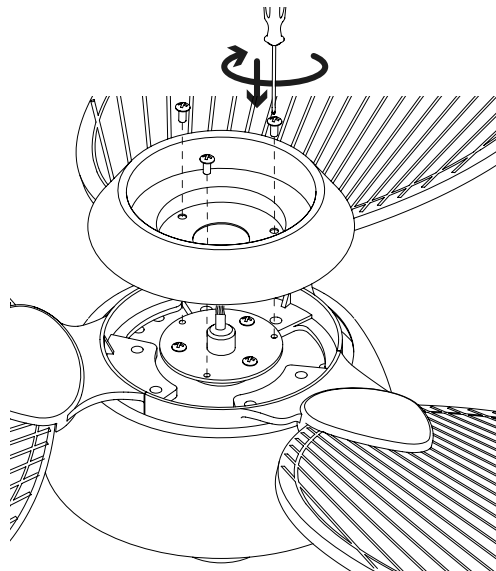

○ GL
Light kit

1

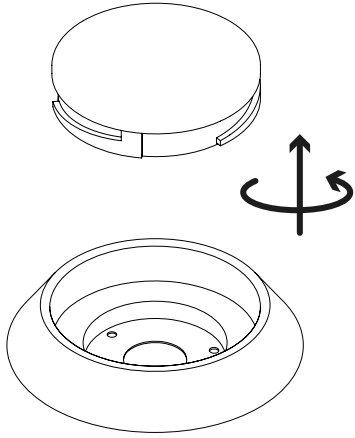

2

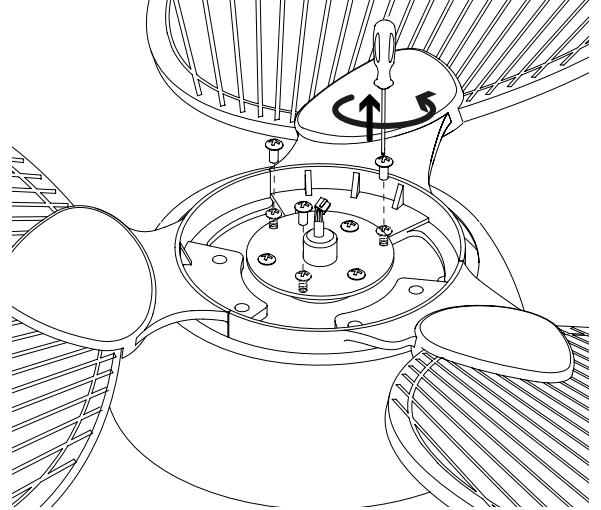

3

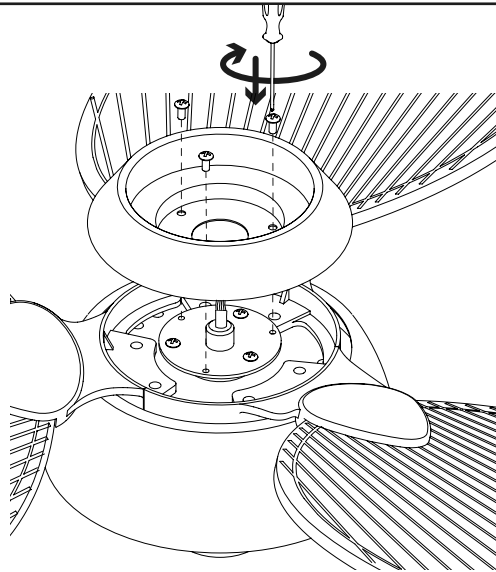

4

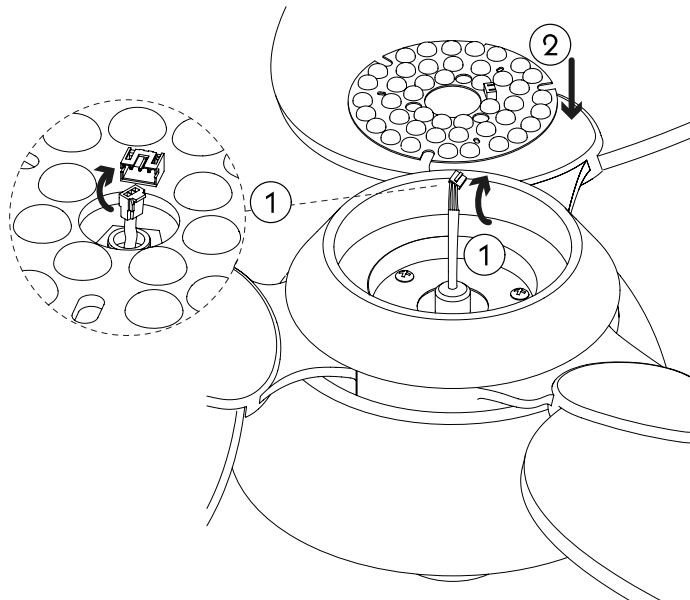

 **CL**
Comfort light kit

1

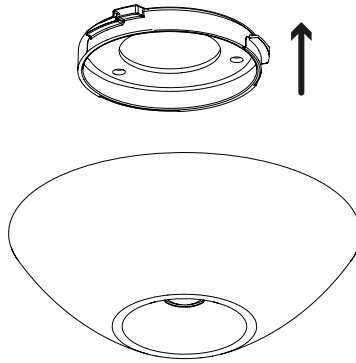

2

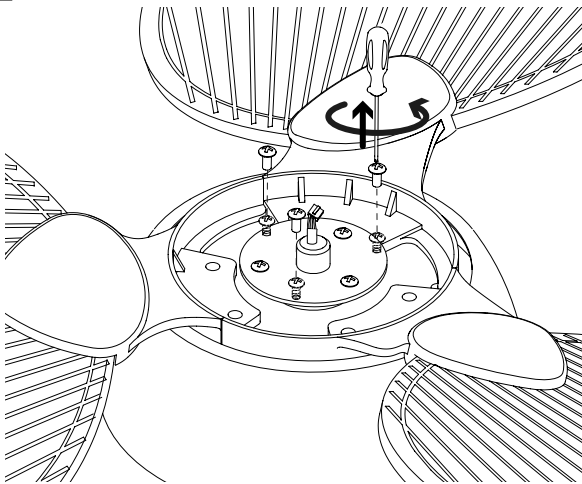

3

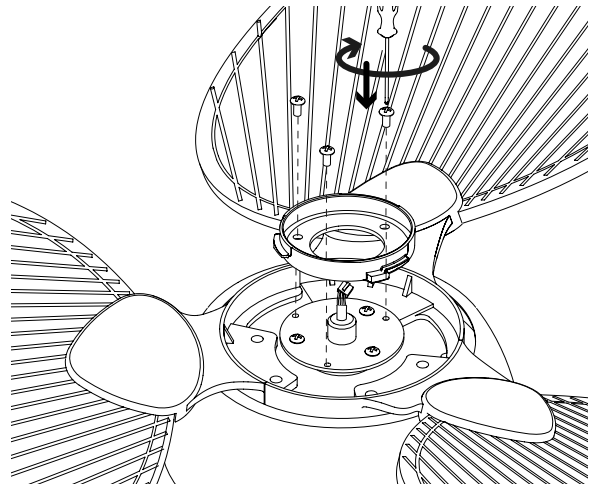

4

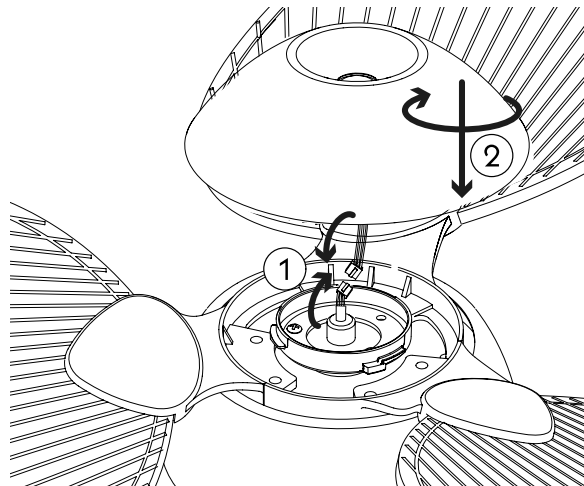

1

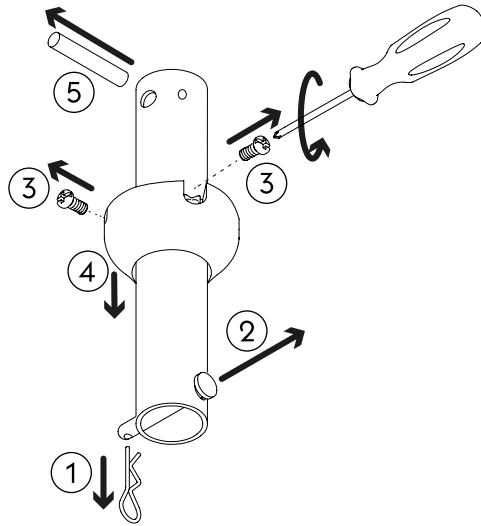

2

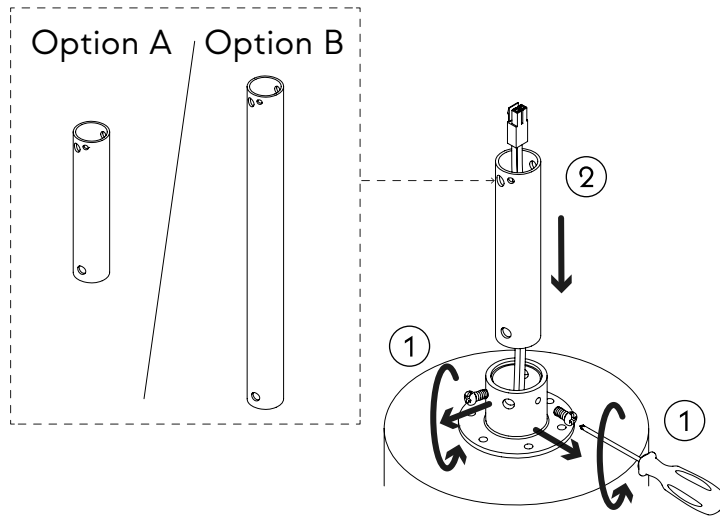

3

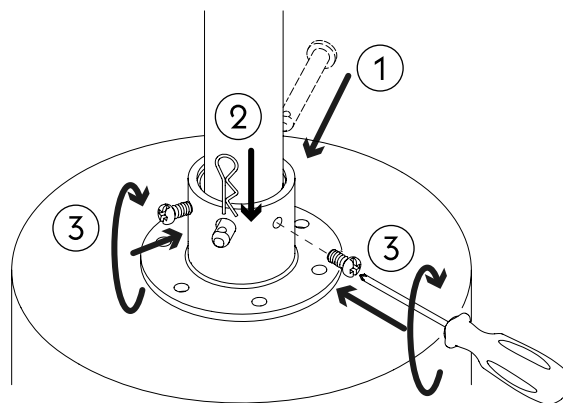

4

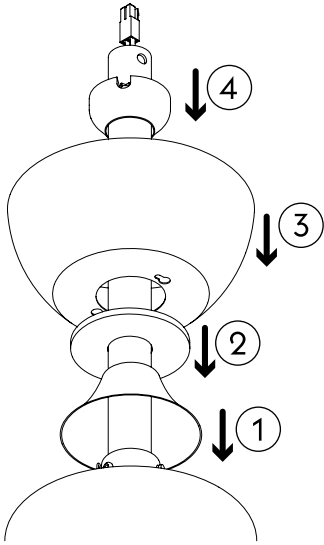

5

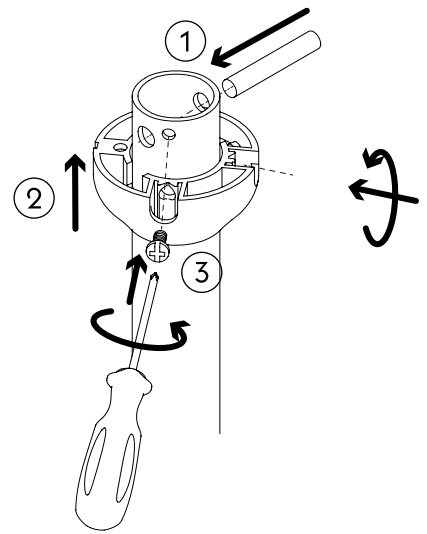

6

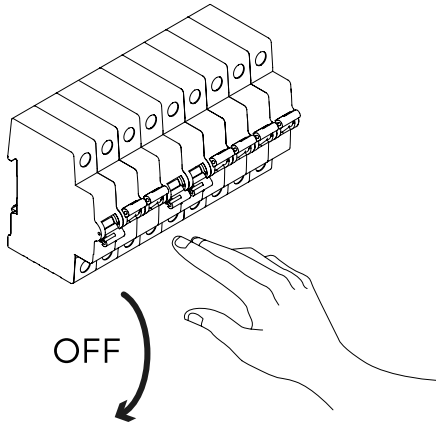

7

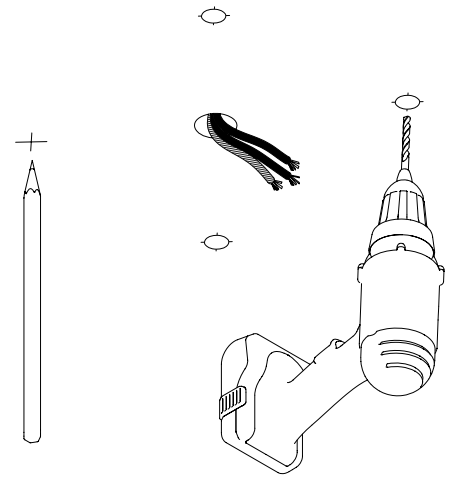

8

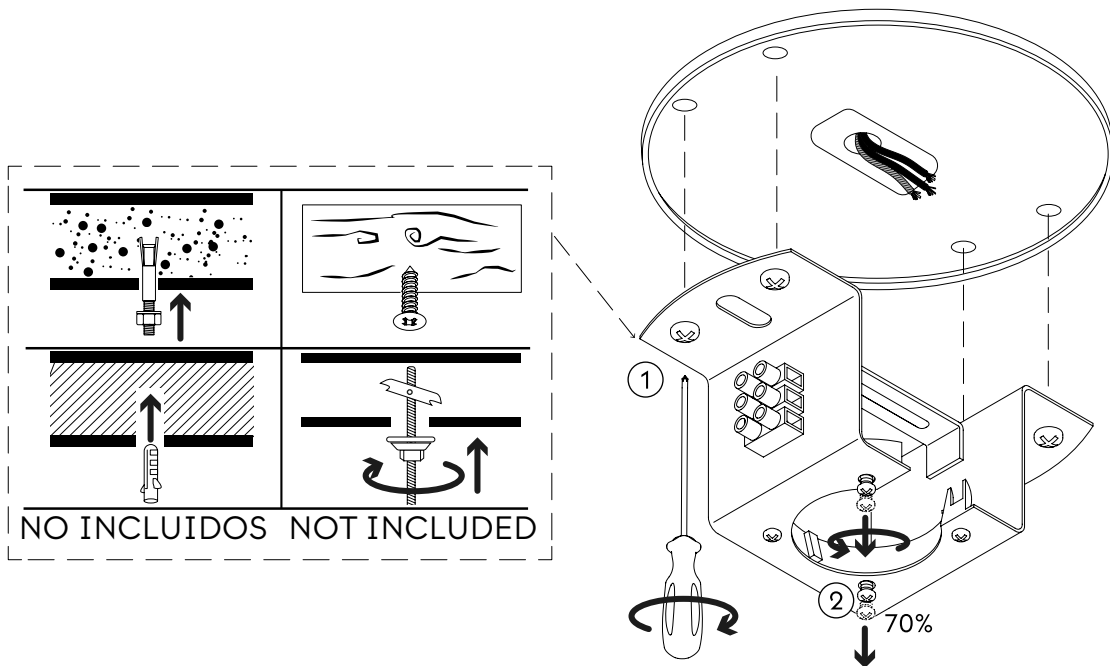

9 _____

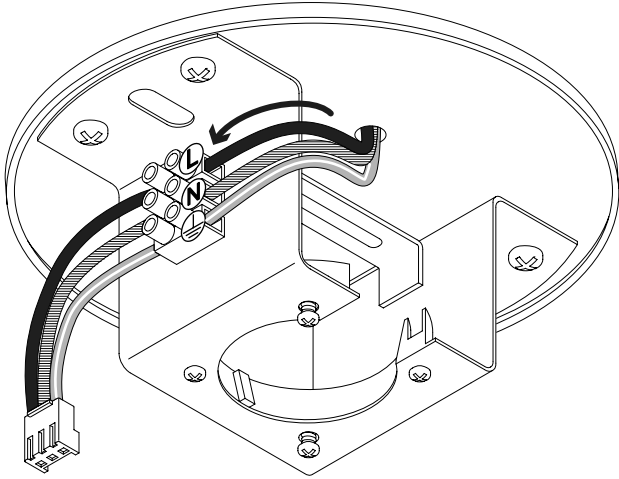

10 _____

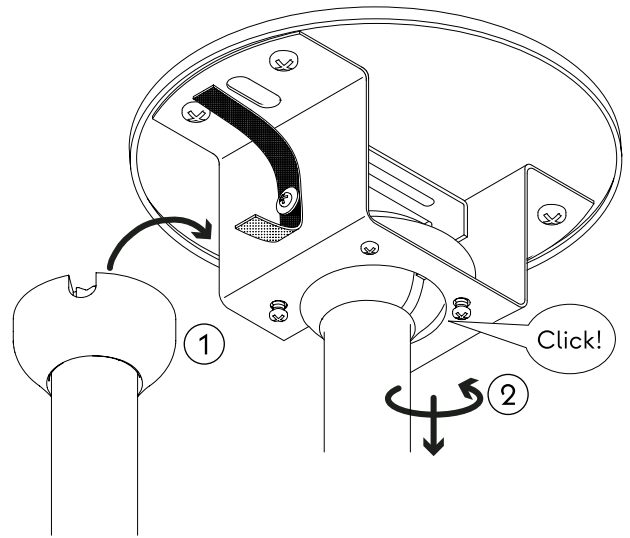

11 _____

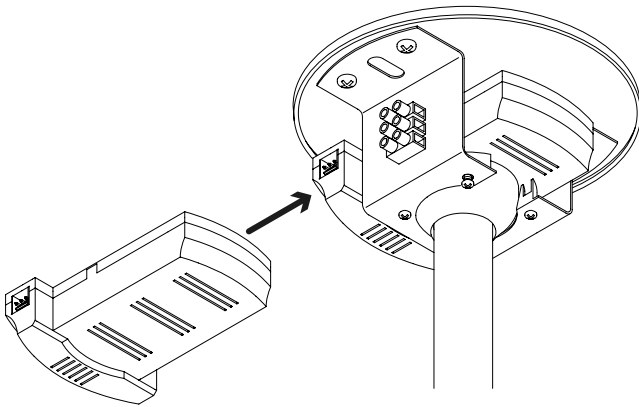

12 _____

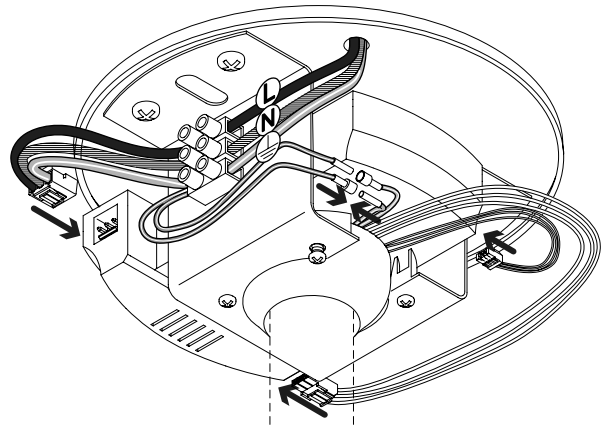

13 _____

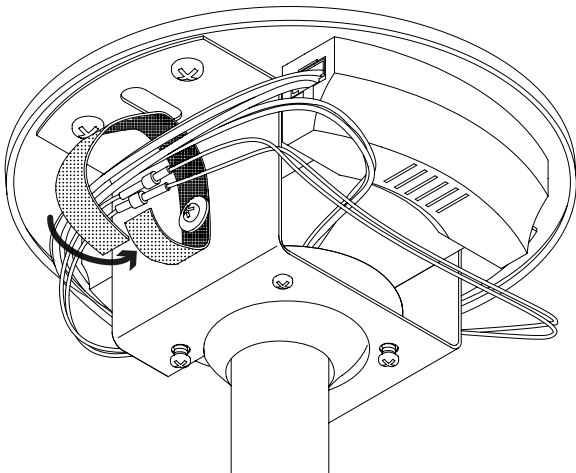

14 _____

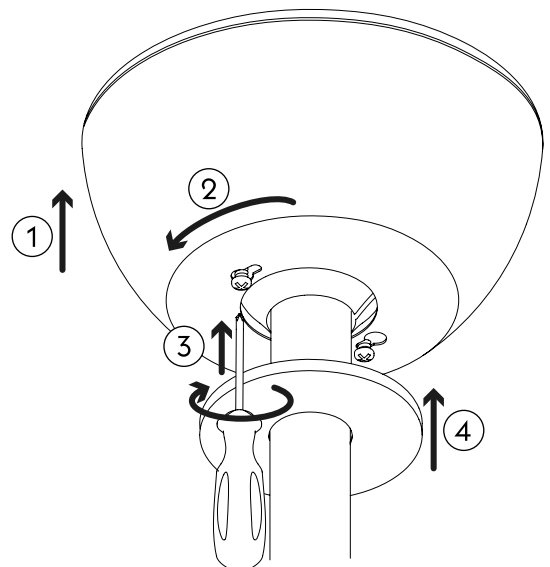

15

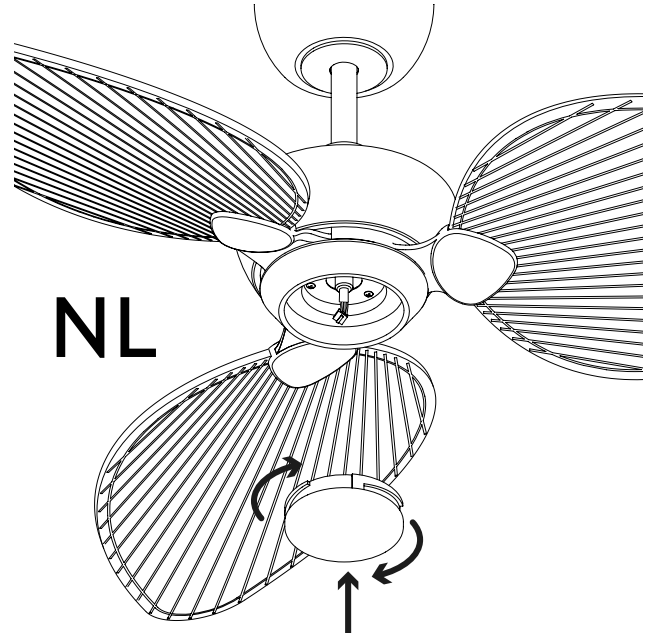
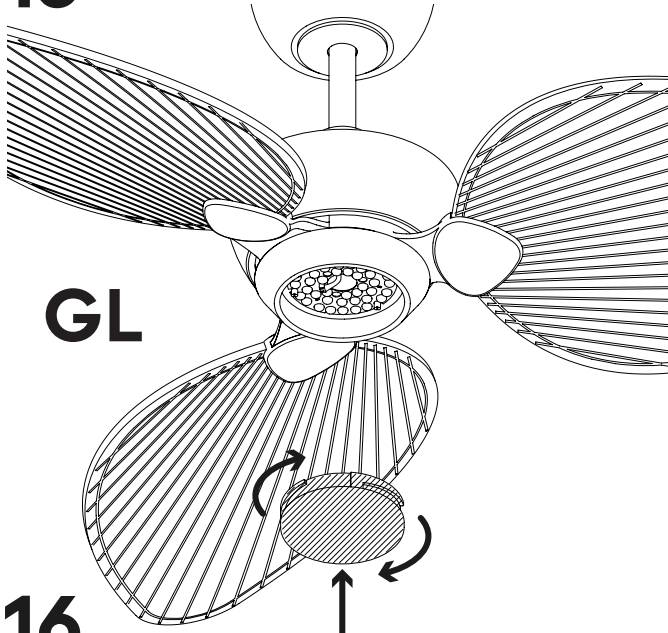

16

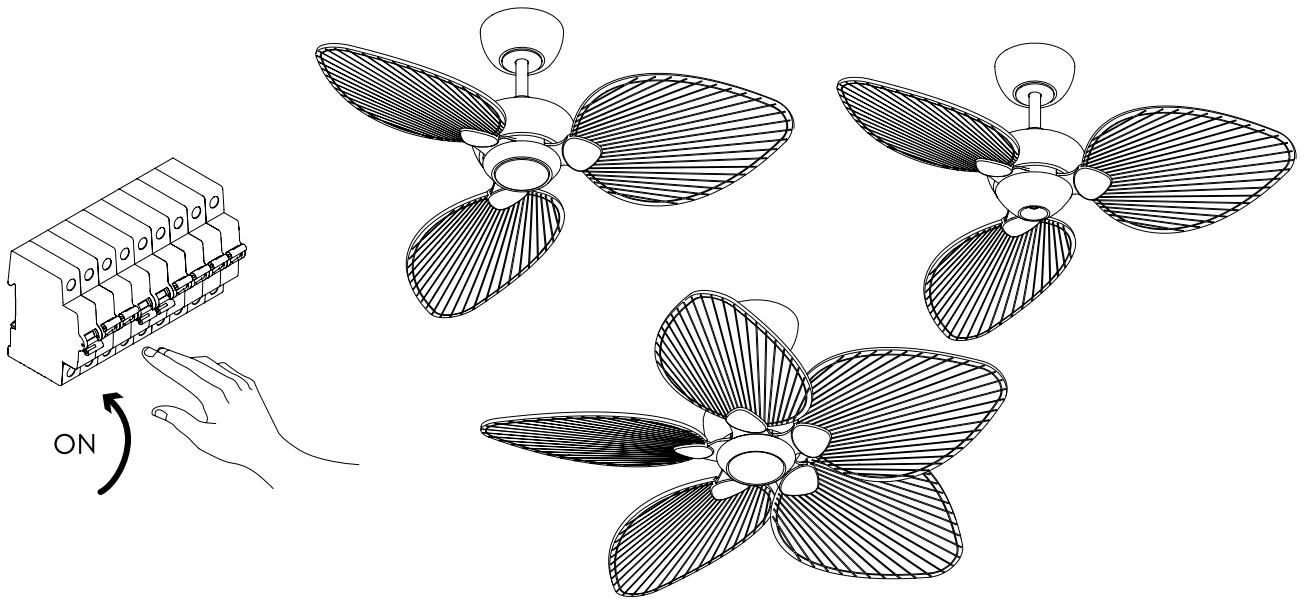

DECLARACIÓN DE CONFORMIDAD CE

SULION declara bajo su propia responsabilidad que los productos con cuyas referencias estan indicadas en la portada de este manual han sido fabricados en conformidad con los siguientes estándares europeos.

EC DECLARATION OF CONFORMITY

SULION declares under its own responsibility that the products with references indicated on the cover of this manual have been manufactured in compliance with the following European standards.

DÉCLARATION DE CONFORMITÉ CE

SULION déclare sous sa propre responsabilité que les produits dont les références sont indiquées sur la couverture de ce manuel ont été fabriqués conformément aux normes européennes suivantes.

DECLARAÇÃO DE CONFORMIDADE CE

A SULION declara sobre a sua própria responsabilidade que os produtos cujas referências estão indicadas na capa deste manual foram fabricados de acordo com as seguintes normas europeias.

EC-KONFORMITÄTSERKLÄRUNG

SULION erklärt in eigener Verantwortung, dass die Produkte, deren Referenzen auf dem Umschlag dieses Handbuchs angegeben sind, in Übereinstimmung mit den folgenden europäischen Normen hergestellt wurden.

DICHIARAZIONE DI CONFORMITÀ CE

SULION dichiara sotto la propria responsabilità che i prodotti le quali referenze vengono indicate sulla copertina di questo manuale sono stati fabbricati in conformità con le seguenti norme europee..

ΔΗΛΩΣΗ ΣΥΜΜΟΡΦΩΣΗΣ ΕΚ

Η SULION δηλώνει υπό την ευθύνη της ότι τα προϊόντα που αναφέρονται στο εξώφυλλο του εγχειριδίου έχουν κατασκευαστεί σύμφωνα με τα παρακάτω Ευρωπαϊκά πρότυπα.

● NL No light

Directive RED 2014/35/EU	Article 3.1a	EN 60335-1:2012 + A11:2014 + A13:2017 + A1:2019 + A14:2019 + A2:2019
		EN 60335-2-80:2003 + A1:2004 + A2:2009
		EN 62233:2008
		EN IEC 60598-2-1:1989
Directive RED 2014/35/EU	Article 3.1b	EN 55014-1:2017 + A11:2020
		EN 55014-2:1997 + A1:2001 + A2:2008
		EN 55015:2019 + A11:2020
		EN 61547:2009
		EN 301 489-1 V2.2.3
		EN 301 489-3 V2.1.1
Directive RoHS 2015/863/EU	Article 3.2	EN 300 220-1 V3.1.1
		EN 300 220-2 V3.2.1
ErP Directive 2009/125/EC		Regulation 206/2012
		IEC 60879:2019

Directive RED 2014/35/EU	Article 3.1a	EN 60598-1:2015 + A1:2018
		EN 62471:2008
		EN 62493:2010
		EN 60335-1:2012 + A11:2014 + A13:2017 + A1:2019 + A14:2019 + A2:2019
		EN 60335-2-80:2003 + A1:2004 + A2:2009
		EN 62233:2008
		EN 62031:2008 + A1:2013 + A2:2015
		EN IEC 60598-2-1:1989
	Article 3.1b	EN 55014-1:2017 + A11:2020
		EN 55014-2:1997 + A1:2001 + A2:2008
		EN 55015:2019 + A11:2020
		EN 61547:2009
		EN 61000-3-2:2019
		EN 61000-3-3:2013
		EN 301 489-1 V2.2.3
EN 301 489-3 V2.1.1		
Article 3.2	EN 300 220-1 V3.1.1	
	EN 300 220-2 V3.2.1	
Directive RoHS 2015/863/EU		UNE-EN IEC 63000:2018
ErP Directive 2009/125/EC		Regulation 2019/2020
		Regulation 206/2012
		IEC 60879:2019

SULION DIGITAL S.A.

Madrid, 13/01/2026

C. Schuller

CEO



sulion.es

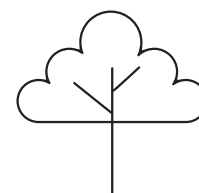

ES Elige reparar, no desperdiciar.

Nuestro propósito es generar un impacto positivo en el medio ambiente y en la sociedad. Ofrecemos repuestos fáciles de instalar para evitar devoluciones y reducir residuos. Contacte con nosotros para soluciones responsables y visite sulion.es para consejos sobre sostenibilidad y eficiencia energética. Juntos creamos los espacios del mañana.

EN Choose to repair, not to waste.

Our purpose is to generate a positive impact on the environment and society. We offer easy-to-install spare parts to avoid returns and reduce waste. Contact us for responsible solutions and visit sulion.es for tips on sustainability and energy efficiency. Together, we create the spaces of tomorrow.

FR Choisissez de réparer, pas de gaspiller.

Notre objectif est de générer un impact positif sur l'environnement et la société. Nous proposons des pièces de rechange faciles à installer pour éviter les retours et réduire les déchets. Contactez-nous pour des solutions responsables et visitez sulion.es pour des conseils sur la durabilité et l'efficacité énergétique. Ensemble, nous créons les espaces de demain.

PT Escolha reparar, não desperdiçar.

Nosso propósito é gerar um impacto positivo no meio ambiente e na sociedade. Oferecemos peças de reposição fáceis de instalar para evitar devoluções e reduzir resíduos. Entre em contato conosco para soluções responsáveis e visite sulion.es para dicas sobre sustentabilidade e eficiência energética. Juntos, criamos os espaços de amanhã.

DE Wählen Sie Reparieren statt Wegwerfen.

Unser Ziel ist es, einen positiven Einfluss auf die Umwelt und die Gesellschaft zu haben. Wir bieten einfach zu installierende Ersatzteile an, um Rücksendungen zu vermeiden und Abfall zu reduzieren. Kontaktieren Sie uns für verantwortungsbewusste Lösungen und besuchen Sie sulion.es für Tipps zu Nachhaltigkeit und Energieeffizienz. Gemeinsam gestalten wir die Räume von morgen.

IT Scegli di riparare, non di sprecare.

Il nostro obiettivo è generare un impatto positivo sull'ambiente e sulla società. Offriamo pezzi di ricambio facili da installare per evitare resi e ridurre i rifiuti. Contattaci per soluzioni responsabili e visita sulion.es per consigli su sostenibilità ed efficienza energetica. Insieme, creiamo gli spazi di domani.

EL Επιλέξτε να επισκευάσετε, όχι να σπαταλήσετε.

Σκοπός μας είναι να δημιουργήσουμε θετικό αντίκτυπο στο περιβάλλον και στην κοινωνία. Προσφέρουμε εύκολα στην εγκατάσταση ανταλλακτικά για να αποφύγουμε τις επιστροφές και να μειώσουμε τα απόβλητα. Επικοινωνήστε μαζί μας για υπεύθυνες λύσεις και επισκεφθείτε το sulion.es για συμβουλές σχετικά με τη βιωσιμότητα και την ενεργειακή απόδοση. Μαζί δημιουργούμε τους χώρους του αύριο.

