

# Sulion

## Bombay Estilo

**S Ref.:** 2239422 / 2239514 / 2239521 / 2243269 / 2239552

**M Ref.:** 2239439 / 2239538 / 2239545 / 2243276 / 2239569



Video de instalación / Installation  
video / Vidéo d'installation / Video de  
instalação / Installationsvideo / Video  
dell'installazione / Βίντεο εγκατάστασης

**SAT**

sulion.es





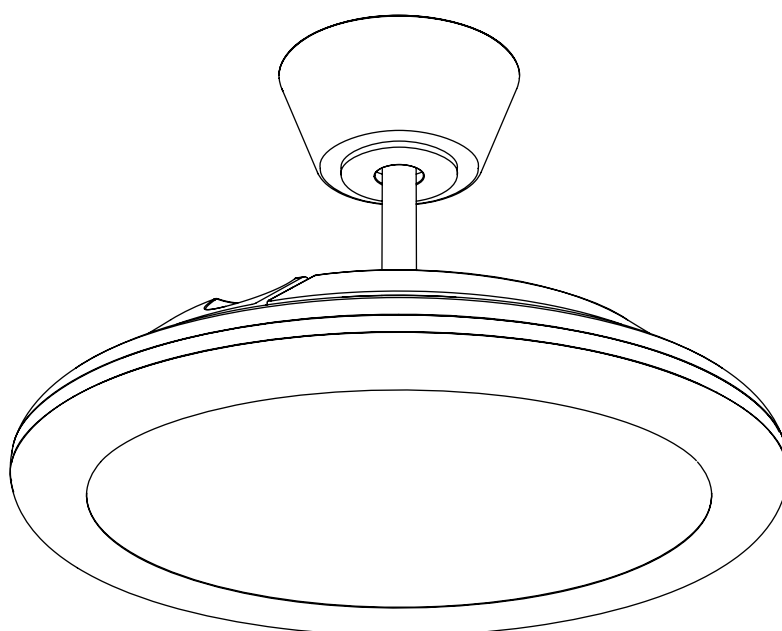

























+34 621262721

sat@sulion.es









# Bombay Estilo S







Ref.: 2239422 / 2239514 / 2239521 / 2243269 / 2239552









 220-240V ~AC A1	$f$ 50/60 Hz A2	 IP 20 A6	 -5 ↔ 40°C A9	 15° A10	kg 4,9 kg A11	 <0,5W A12	
 57 kWh/1000h A13	 4600 lm B1	 26 W B2	 1700 lm B1	 9 W B2	 C B3	CCT 2700 K 4000 K 6500 K B6	 360° B7
 120° B8	 CRI 80 B9	 30.000 h B10	 on off 10.000 B11	 B12	 B15	 B18	 ☆☆☆☆ 5 m³/min/W D7
 3,4 m/s D8	IEC 60879: 2019 D9	 E2	 433.92 MHz E4	 10 dBm E5			
 n° D1	 W D2	 RPM D3	 m³/min D4	 m³/h D5	 dB D6		
1	5	185	66	3960	30		
2	7	210	75	4500	33		
3	8	230	83	4980	35		
4	11	255	92	5520	37		
5	16	280	100	6000	39		
6	22	305	110	6600	41		





# Bombay Estilo M

Ref.: 2239439 / 2239538 / 2239545 / 2243276 / 2239569

 220-240V ~AC	$f$ 50/60 Hz		 IP 20	 -5 ↔ 40°C	 15°	<b>kg</b> 5,9 kg	 <0,5W
A1	A2	A3	A6	A9	A10	A11	A12

 69 kWh/1000h	 4800 lm	 27 W	 1800 lm	 10 W	 C	<b>CCT</b> 2700 K 4000 K 6500 K	 360°
A13	B1	B2	B1	B2	B3	B6	B7

 120°	 <b>CRI</b> 80	 30.000 h	 on off 10.000				 ☆☆☆☆ 3,78 m³/min/W
B8	B9	B10	B11	B12	B15	B18	D7

 3,4 m/s	<b>IEC</b> 60879: 2019		 433.92 MHz	 10 dBm
D8	D9	E2	E4	E5

 n°	 W	 RPM	 m³/min	 m³/h	 dB
D1	D2	D3	D4	D5	D6

1	5	170	80	4800	30
2	7	185	87	5220	33
3	9	200	94	5640	36
4	13	215	101	6060	39
5	23	240	113	6780	42
6	32	256	121	7260	45

Herramientas requeridas y componentes / Required tools and components / Outils et composants requis / Ferramentas e componentes necessários / Erforderliche Werkzeuge und Komponenten / Strumenti necessari e componenti / Απαιτούμενα εργαλεία και εξαρτήματα

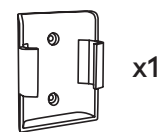
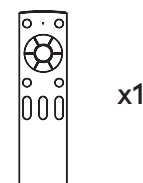
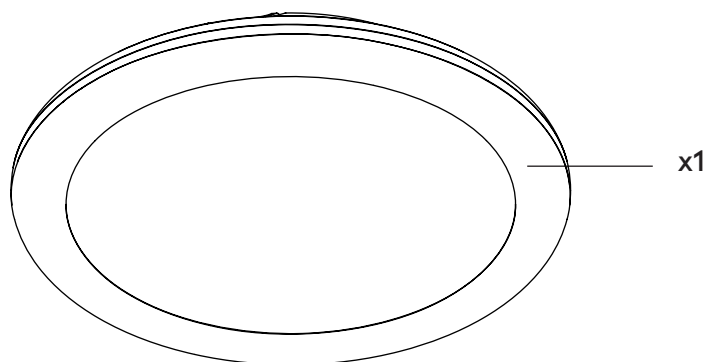
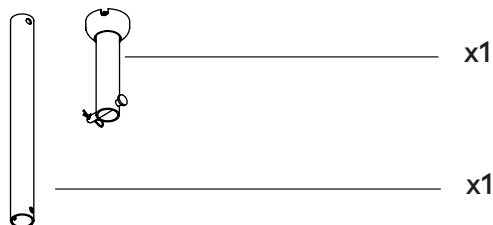
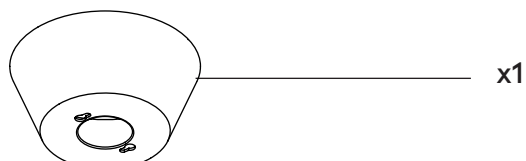
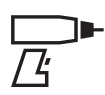

**ES** Solución de incidencias / FAQ. Preguntas frecuentes / Control de dos o más ventiladores con un único control remoto  
**EN** Troubleshooting / FAQ. Frequently asked questions / Control two or more fans with a single remote control  
**FR** Dépannage / FAQ. Questions fréquemment posées / Contrôle de deux ou plusieurs ventilateurs avec une seule télécommande

**PT** Solução de problemas / FAQ. Perguntas frequentes / Controlo de dois ou mais ventiladores com um único comando à distância

**DE** Fehlerbehebung / FAQ. Häufig gestellte Fragen / Steuerung von zwei oder mehr Ventilatoren mit einer einzigen Fernbedienung

**IT** Risoluzione dei problemi / FAQ. Domande frequenti / Controllo di due o più ventilatori con un unico telecomando

**EL** Επίλυση προβλημάτων / FAQ. Συχνές ερωτήσεις / Ρύθμιση δυο ή περισσότερων ανεμιστήρων με ένα τηλεχειριστήριο

1

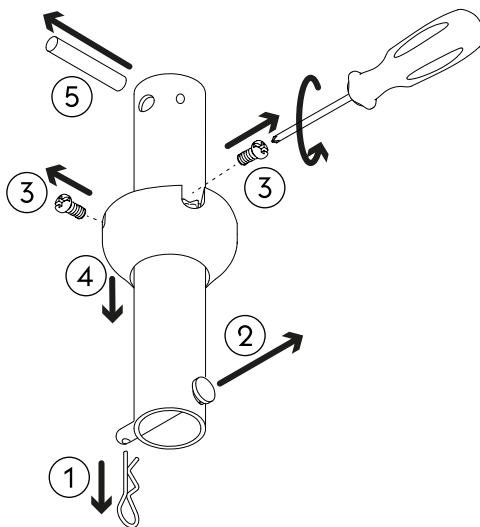

2

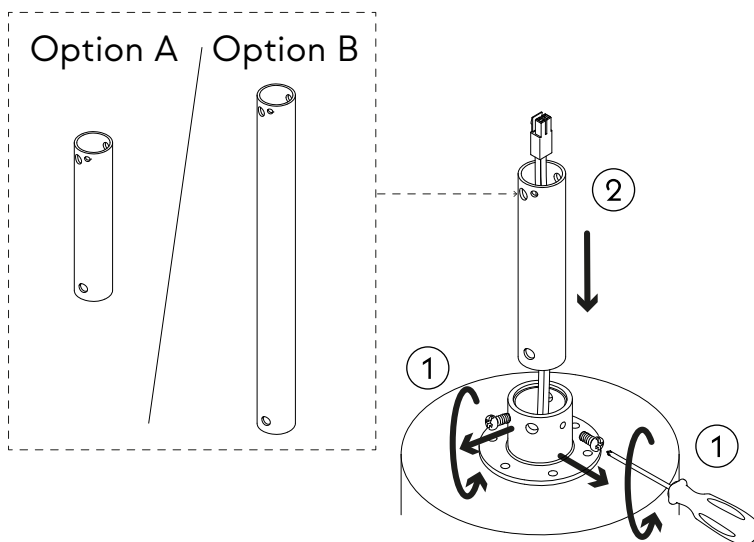

3

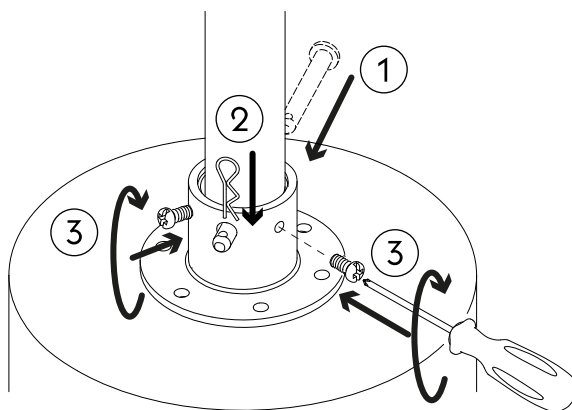

4 \_\_\_\_\_

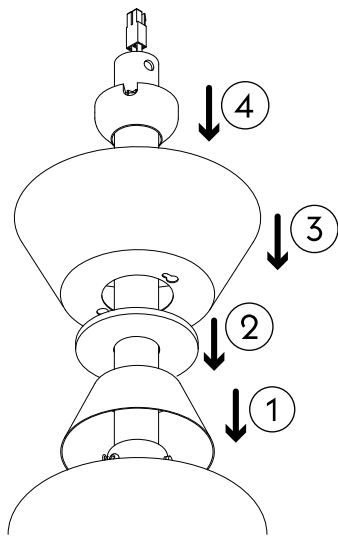

5 \_\_\_\_\_

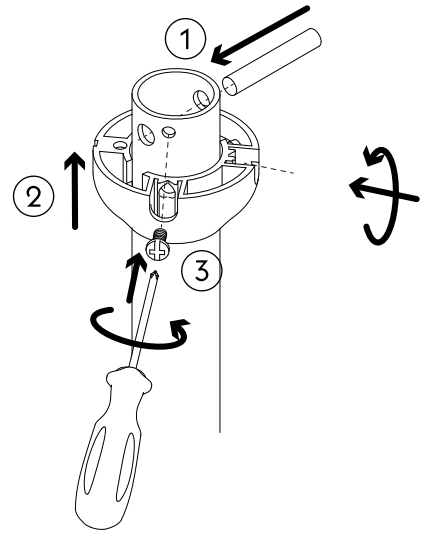

6 \_\_\_\_\_

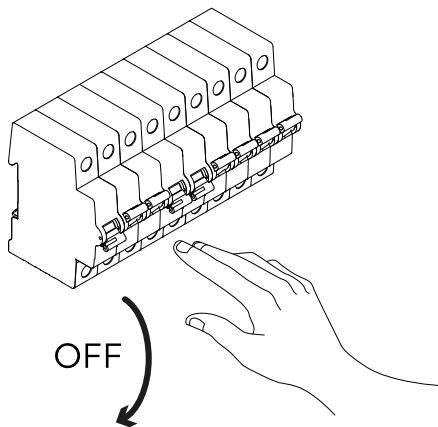

7 \_\_\_\_\_

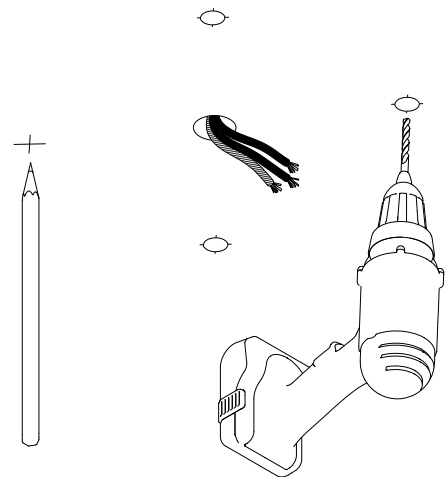

8 \_\_\_\_\_

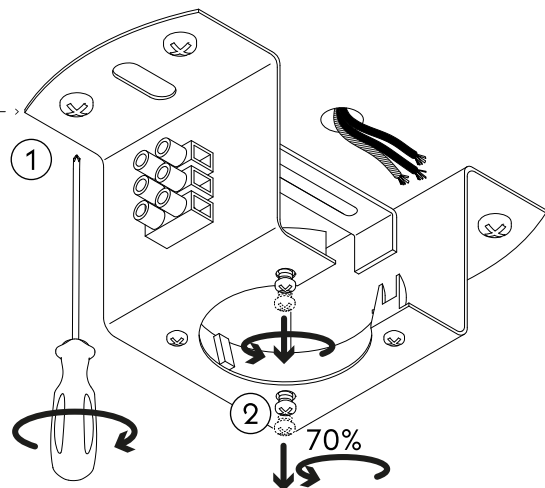
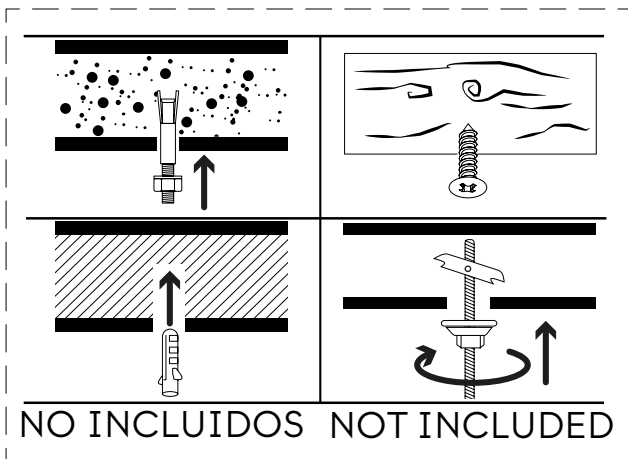

# 9

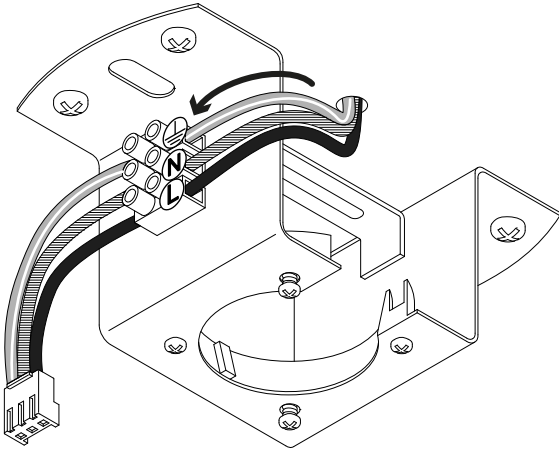

# 10

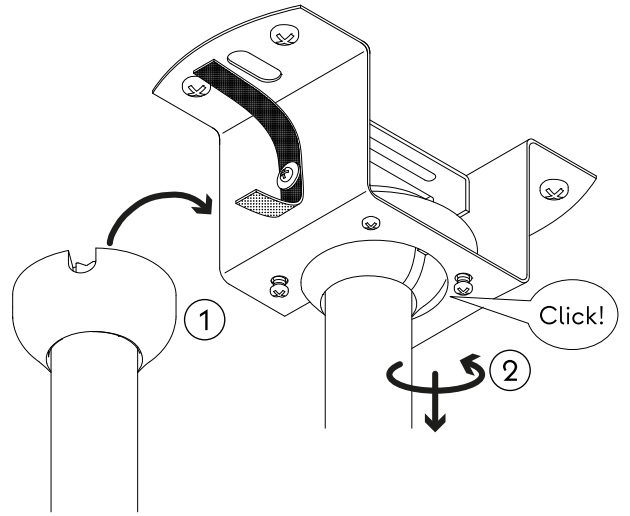

# 11

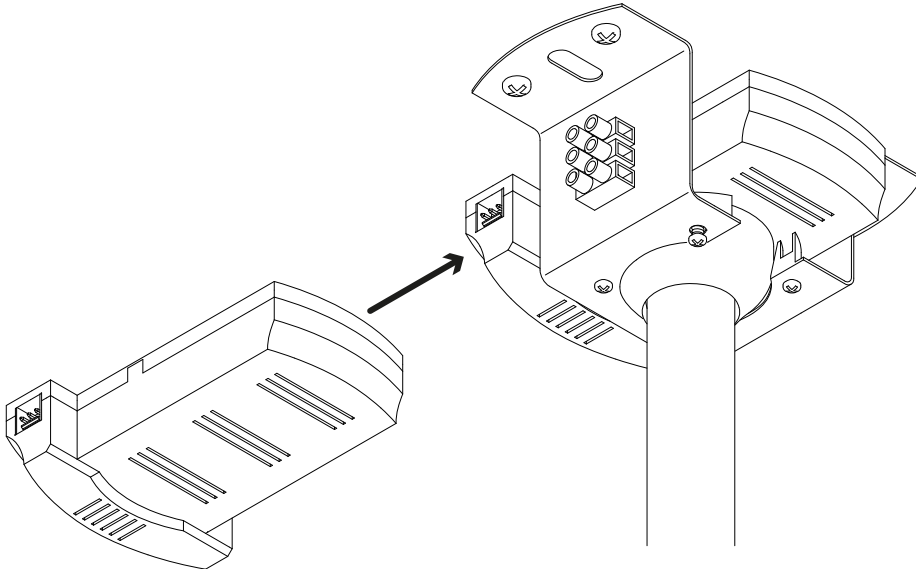

# 12

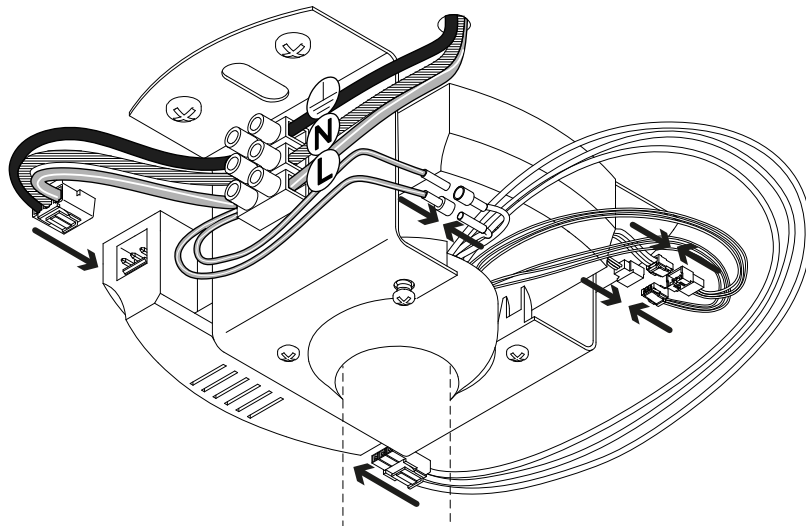

13

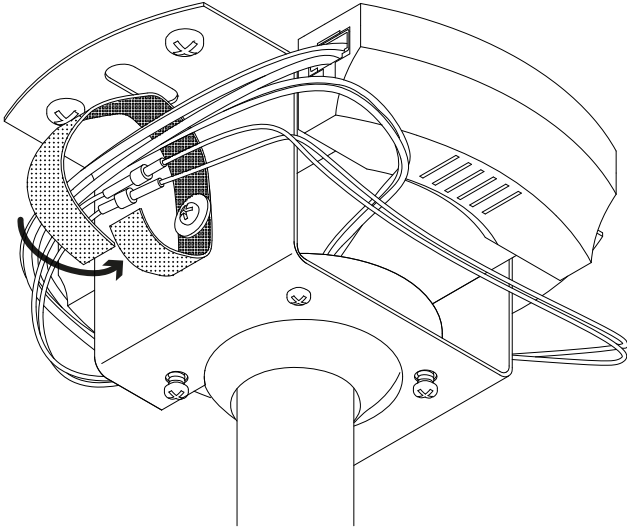

14

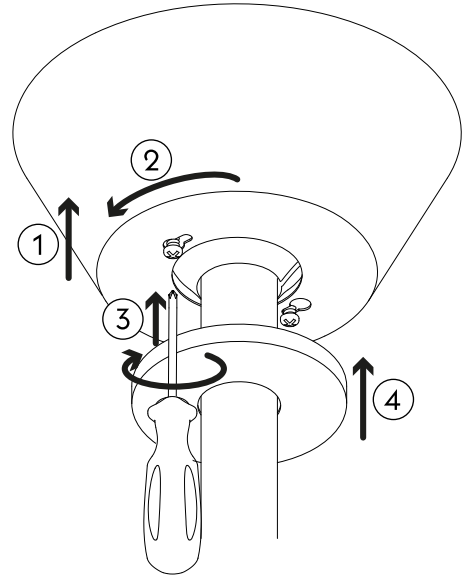

15

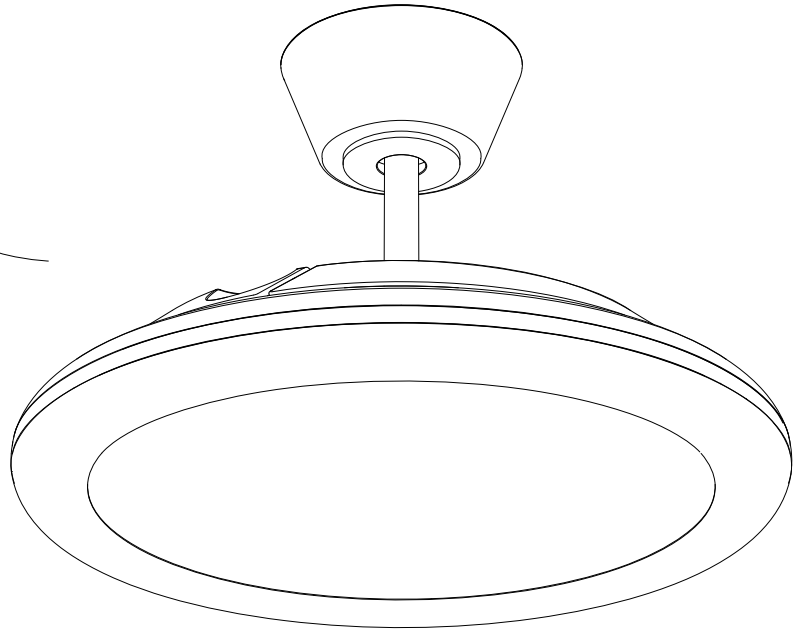
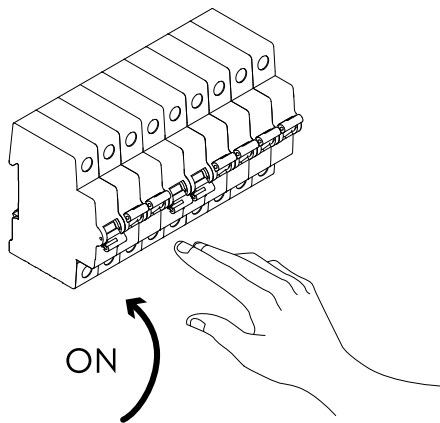



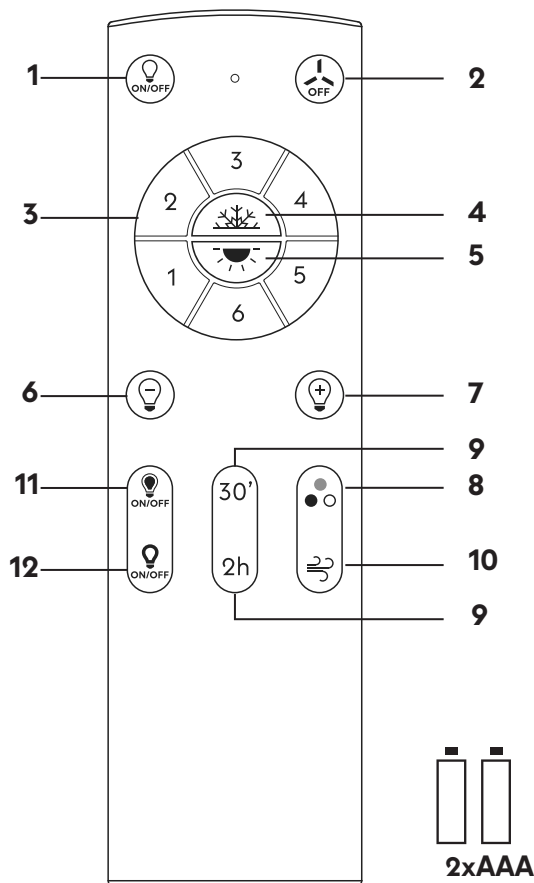

## Control Remoto

1. Encender y apagar luces.
2. Apagar ventilador.
3. Encender distintas velocidades del ventilador.
4. *Cool mode*: la corriente de aire descendiente crea efecto refrescante.
5. *Warm mode*: la corriente de aire ascendente reparte el aire caliente homogeneizando la temperatura de la estancia.
6. Disminuir intensidad de la luz.
7. Aumentar intensidad de la luz.
8. Cambiar temperatura de color
9. Temporizador 30' / 2h. Programación de apagado del ventilador pasados 30 minutos / 2 horas. Si se presiona cualquier botón después de haber seleccionado una programación de apagado esta se anulará. Pulsar varias veces el botón reinicia el tiempo.
10. Viento natural. Sube y baja la velocidad del ventilador de manera automática generando un efecto brisa. Para activar esta función el ventilador debe estar previamente girando a una determinada velocidad. Presionando cualquier botón de velocidad se interrumpe.
11. Encender y apagar luz principal
12. Encender y apagar luz perimetral.

## Programaciones especiales

- **Modo memoria ventilador:** El ventilador se enciende en la última velocidad usada al encender desde el interruptor de pared. Para activar o desactivar esta función, apaga y enciende desde el interruptor de pared y, antes de que pasen 5 segundos, presione las velocidades **1** y **5** del mando hasta que suene un bip. Viene desactivado por defecto.
- **Modo sonido mando:** Cada vez que presione cualquier botón del mando sonará un bip en el ventilador si ha recibido la señal. Para activar o desactivar esta función, apaga y enciende desde el interruptor de pared y, antes de que pasen 5 segundos, presione los botones **30'** y **2h** del mando hasta que suene un bip. Viene desactivado por defecto.

## Remote control

1. Turn on and off lights.
2. Turn off fan.
3. Turn on different fan speeds.
4. *Cool mode*: the downward air current creates a cooling effect.
5. *Warm mode*: the ascending air flow distributes the heat air homogenizing the temperature of the room.
6. Decrease light intensity.
7. Increase light intensity.
8. Change color temperature
9. 30' / 2h timer. Fan switch-off setting after 30 minutes / 2 hours. Pressing any button after selecting a switch-off setting will cancel it. Pressing the button several times resets the time.
10. Natural wind. Automatically increases and decreases the fan speed, creating a breeze effect. To activate this function, the fan must be previously rotating at a certain speed. Pressing any speed button will stop the function.
11. Turn on and off main light.
12. Turn on and off perimeter light.

## Special programs

- **Fan memory mode:** The fan turns on at the last speed used when turned on from the wall switch. To activate or deactivate this function, turn the power off and on from the wall switch and, within 5 seconds, press speeds **1** and **5** on the remote control until a beep sounds. It is disabled by default.
- **Remote control sound mode:** It is disabled by default. Every time you press any button on the remote control, a beep will sound on the fan if it has received the signal. To activate or deactivate this function, turn the power off and on from the wall switch and, within 5 seconds, press the **30'** and **2h** buttons on the remote control until a beep sounds. It is disabled by default.

## Télécommande

1. Allumer et éteindre les lumières
2. Éteignez le ventilateur.
3. Allumez différentes vitesses de ventilateur.
4. *Cool mode*: le courant d'air descendant crée un effet rafraîchissant.
5. *Warm mode*: le flux d'air ascendant distribue l'air chaud, homogénéisant la température dans la pièce..
6. Réduisez l'intensité lumineuse.
7. Augmentez l'intensité lumineuse.
8. Changer la température de couleur
9. Minuterie 30'/2h. Programmation d'arrêt du ventilateur après 30 minutes / 2 heures. Appuyer sur n'importe quel bouton après avoir sélectionné un programme d'arrêt l'annulera. En appuyant plusieurs fois sur le bouton, l'heure est réinitialisée.
10. Vent naturel. Augmente et diminue automatiquement la vitesse du ventilateur, générant un effet de brise. Pour activer cette fonction, le ventilateur doit préalablement tourner à une certaine vitesse. Appuyer sur n'importe quel bouton de vitesse l'interrompt.
11. Allumer et éteindre la lumière principale.
12. Allumer et éteindre la lumière périmétrique.

## Programmation spéciale

- **Mode mémoire du ventilateur :**Le ventilateur s'allume à la dernière vitesse utilisée lors de la mise sous tension à partir de l'interrupteur mural. Pour activer ou désactiver cette fonction, éteignez et rallumez l'appareil à partir de l'interrupteur mural et, dans les 5 secondes, appuyez sur les vitesses **1** et **5** de la télécommande jusqu'à ce qu'un bip retentisse. Il est désactivé par défaut.
- **Mode son à distance :** Chaque fois que vous appuyez sur un bouton de la télécommande, un bip retentira sur le ventilateur s'il a reçu le signal. Pour activer ou désactiver cette fonction, éteignez-la et rallumez-la depuis l'interrupteur mural et, dans les 5 secondes, appuyez sur les boutons **30'** et **2h** de la télécommande jusqu'à ce qu'un bip retentisse. Il est désactivé par défaut.

# Portugues

## Controle remoto

1. Acender e apagar luzes
2. Desligue o ventilador.
3. Ligue diferentes velocidades do ventilador.
4. *Cool mode*: a corrente de ar descendente cria um efeito refrescante.
5. *Warm mode*: o fluxo de ar ascendente distribui o ar quente, homogeneizando a temperatura na divisão.
6. Reduza a intensidade da luz.
7. Aumente a intensidade da luz.
8. Alterar temperatura de cor
9. Temporizador 30'/2h. Programação de paragem do ventilador após 30 minutos/2 horas. Pressionar qualquer botão após a seleção de uma programação de paragem irá substituí-la. Pressionar o botão várias vezes faz reset à hora.
10. Vento natural. Aumenta e diminui automaticamente a velocidade do ventilador, gerando um efeito de brisa. Para ativar esta função é necessário que o ventilador esteja previamente a rodar a uma determinada velocidade. Pressionar qualquer botão de velocidade interrompe-o.
11. Acender e apagar luz principal.
12. Acender e apagar luz perimetral.

## Programação especial

• **Modo de memória do ventilador:** O ventilador liga à última velocidade utilizada ao ligar o interruptor de parede. Para ativar ou desativar esta função, desligue e ligue o interruptor de parede e, no espaço de 5 segundos, pressione as velocidades **1** e **5** no comando até ouvir um sinal sonoro. Está desligado por padrão.

• **Modo de som remoto:** Cada vez que premir qualquer botão do telecomando, soará um sinal sonoro no ventilador se este tiver recebido o sinal. Para ativar ou desativar esta função, desligue e ligue-a no interruptor de parede e, no espaço de 5 segundos, pressione os botões **↔** e **2h** do comando até ouvir um sinal sonoro. Está desligado por padrão.

# Italiano

## Control Remoto

1. Accendere e spegnere le luci.
2. Spegner il ventilatore
3. Attivare diverse velocità del ventilatore.
4. *Cool mode*: la corrente d'aria discendente crea un effetto rinfrescante.
5. *Warm mode*: il flusso d'aria ascendente distribuisce l'aria calda, omogeneizzando la temperatura nella stanza.
6. Ridurre l'intensità della luce.
7. Aumentare l'intensità della luce.
8. Cambiare la temperatura del colore.
9. Timer 30'/2h. Programmazione dello spegnimento del ventilatore dopo 30 minuti/2 ore. Se si pulsa un pulsante qualsiasi dopo aver selezionato un programma di spegnimento, il timer verrà annullato. Premendo più volte il pulsante si ripristina il tempo.
10. Vento naturale. Aumenta e diminuisce automaticamente la velocità della ventola, generando un effetto brezza. Per attivare questa funzione è necessario che la ventola ruoti preventivamente ad una certa velocità. Premendo qualsiasi pulsante di velocità, l'effetto vento naturale si interrompe.
11. Accendere e spegnere la luce principale.
12. Accendere e spegnere la luce perimetrale

## Programmazione speciale

• **Modalità memoria ventilatore:** Il ventilatore si accende all'ultima velocità utilizzata durante l'accensione dall'interruttore a parete. Per attivare o disattivare questa funzione, spegnere e riaccendere il ventilatore dall'interruttore a parete e, entro 5 secondi, premere le velocità **1** e **5** sul telecomando finché non viene emesso un segnale acustico. Viene disabilitato per difetto.

• **Modalità audio telecomando:** Ogni volta che si preme un pulsante qualsiasi del telecomando, il ventilatore emetterà un segnale acustico se ha ricevuto il segnale. Per attivare o disattivare questa funzione, spegnere e riaccendere il ventilatore dall'interruttore a parete e, entro 5 secondi, premere i pulsanti **↔** e **2h** del telecomando fino all'emissione di un segnale acustico. Viene disabilitato per difetto.

# Deutsch

## Fernbedienung

1. Lichter ein- und ausschalten.
2. Ventilator ausschalten.
3. Schalten Sie verschiedene Lüftergeschwindigkeiten ein.
4. *Cool mode*: der Abwind erzeugt einen Kühleffekt.
5. *Warm mode*: der nach oben gerichtete Luftstrom verteilt die warme Luft und gleicht die Temperatur im Raum aus.
6. Lichtintensität reduzieren.
7. Erhöhen Sie die Lichtintensität.
8. Farbtemperatur ändern
9. Timer 30'/2h. Programmierung der Lüfterabschaltung nach 30 Minuten / 2 Stunden. Durch Drücken einer beliebigen Taste, nachdem ein Abschaltplan ausgewählt wurde, wird dieser überschrieben. Durch mehrmaliges Drücken der Taste wird die Uhrzeit zurückgesetzt.
10. Natürlicher Wind. Erhöht und senkt automatisch die Ventilatorgeschwindigkeit und erzeugt so einen Brise-Effekt. Um diese Funktion zu aktivieren, muss der Ventilator zuvor mit einer bestimmten Geschwindigkeit rotieren. Durch Drücken einer beliebigen Geschwindigkeitstaste wird der Vorgang unterbrochen.
11. Hauptlicht ein- und ausschalten.
12. Perimeterlicht ein- und ausschalten.

## Sonderprogrammierung

• **Lüfterspeichermodus:** Der Ventilator schaltet sich mit der letzten Geschwindigkeit ein, die beim Einschalten über den Wandschalter verwendet wurde. Um diese Funktion zu aktivieren oder zu deaktivieren, schalten Sie das Gerät über den Wandschalter aus und wieder ein und drücken Sie innerhalb von 5 Sekunden die Geschwindigkeitsstufen **1** und **5** auf der Fernbedienung, bis ein Piepton ertönt. Es ist standardmäßig deaktiviert.

• **Piepton der Fernbedienung:** Jedes Mal, wenn Sie eine beliebige Taste auf der Fernbedienung drücken, ertönt ein Piepton am Ventilator, sofern dieser das Signal empfangen hat. Um diese Funktion zu aktivieren oder zu deaktivieren, schalten Sie sie über den Wandschalter aus und wieder ein und drücken Sie innerhalb von 5 Sekunden die Tasten **↔** und **2h** auf der Fernbedienung, bis ein Piepton ertönt. Es ist standardmäßig deaktiviert.

# Ελληνικά

## Τηλεχειριστήριο

1. Άναψε και σβήσε τα φώτα
2. Απενεργοποίηση ανεμιστήρα.
3. Ενεργοποίηση διάφορων ταχυτήτων του ανεμιστήρα.
4. *Cool mode*: Το καθοδικό ρεύμα αέρα δημιουργεί ένα δροσερό αεράκι.
5. *Warm mode*: Η ανοδική ροή αέρα διανέμει τον ζεστό αέρα, ομογενοποιώντας τη θερμοκρασία στο δωμάτιο..
6. Μείωση έντασης του φωτός.
7. Αύξηση έντασης του φωτός.
8. Αλλαγή θερμοκρασίας χρώματος
9. Χρονοδιακόπτης 30' / 2ώρες. Προγραμματισμός απενεργοποίησης του ανεμιστήρα μετά από 30 λεπτά / 2 ώρες. Αν πατήσετε οποιοδήποτε κουμπί εφόσον έχετε επιλέξει ένα πρόγραμμα απενεργοποίησης, αυτό θα ακυρωθεί. Πατώντας αρκετές φορές το κουμπί ο χρόνος επανεκκινείται.
10. Φυσικός αέρας. Αυξάνει και μειώνει αυτόματα την ταχύτητα του ανεμιστήρα δημιουργώντας ένα αεράκι. Για να ενεργοποιήσετε την λειτουργία, ο ανεμιστήρας πρέπει πρώτα να περιστρέφεται σε συγκεκριμένη ταχύτητα. Πατώντας οποιοδήποτε κουμπί η ταχύτητα διακόπτεται.
11. Άναψε και σβήσε το κύριο φως.
12. Άναψε και σβήσε το περιμετρικό φως.

## Ειδικά προγράμματα

• **Λειτουργία μνήμη ανεμιστήρα:** Ο ανεμιστήρας ενεργοποιείται στην τελευταία ταχύτητα που χρησιμοποιήθηκε όταν ανάψει από τον διακόπτη τοίχου. Για ενεργοποίηση ή απενεργοποίηση της λειτουργίας, ανάψει και σβήστε από τον διακόπτη τοίχου και, προτού περάσουν 5 δευτερόλεπτα, πατήστε τις ταχύτητες **1** και **5** του χειριστηρίου μέχρι να ακουστεί ένα μπιπ. Είναι απενεργοποιημένη από προεπιλογή.

• **Λειτουργία ήχος χειριστηρίου:** Είναι απενεργοποιημένη από προεπιλογή. Κάθε φορά που πατάτε οποιοδήποτε κουμπί του χειριστηρίου, θα ακούγεται ένα μπιπ στον ανεμιστήρα αν έχει λάβει το σήμα. Για ενεργοποίηση ή απενεργοποίηση της λειτουργίας, ανάψει και σβήστε από τον διακόπτη τοίχου και, προτού περάσουν 5 δευτερόλεπτα, πατήστε τις ταχύτητες **↔** και **2** ώρες του χειριστηρίου μέχρι να ακουστεί ένα μπιπ. Είναι απενεργοποιημένη από προεπιλογή.

## DECLARACIÓN DE CONFORMIDAD CE

SULION declara bajo su propia responsabilidad que los productos con cuyas referencias estan indicadas en la portada de este manual han sido fabricados en conformidad con los siguientes estándares europeos.

## EC DECLARATION OF CONFORMITY

SULION declares under its own responsibility that the products with references indicated on the cover of this manual have been manufactured in compliance with the following European standards.

## DÉCLARATION DE CONFORMITÉ CE

SULION déclare sous sa propre responsabilité que les produits dont les références sont indiquées sur la couverture de ce manuel ont été fabriqués conformément aux normes européennes suivantes.

## DECLARAÇÃO DE CONFORMIDADE CE

A SULION declara sobre a sua própria responsabilidade que os produtos cujas referências estão indicadas na capa deste manual foram fabricados de acordo com as seguintes normas europeias.

## EC-KONFORMITÄTSERKLÄRUNG

SULION erklärt in eigener Verantwortung, dass die Produkte, deren Referenzen auf dem Umschlag dieses Handbuchs angegeben sind, in Übereinstimmung mit den folgenden europäischen Normen hergestellt wurden.

## DICHIARAZIONE DI CONFORMITÀ CE

SULION dichiara sotto la propria responsabilità che i prodotti le quali referenze vengono indicate sulla copertina di questo manuale sono stati fabbricati in conformità con le seguenti norme europee.

## ΔΗΛΩΣΗ ΣΥΜΜΟΡΦΩΣΗΣ ΕΚ

Η SULION δηλώνει υπό την ευθύνη της ότι τα προϊόντα που αναφέρονται στο εξώφυλλο του εγχειριδίου έχουν κατασκευαστεί σύμφωνα με τα παρακάτω Ευρωπαϊκά πρότυπα.

<b>Directive RED 2014/35/EU</b>	<b>Article 3.1a</b>	EN IEC 60598-1:2021 + A1:2022
		EN 62471:2008
		EN 62493:2015
		EN 60335-1:2012 + A11:2014 + A13:2017 + A1:2019 + A14:2019 + A2:2019
		EN 60335-2-80:2003 + A1:2004 + A2:2009
		EN 62233:2008
		EN 62031:2020 + A11:2021
		EN IEC 60598-2-1:2021
<b>Directive RED 2014/35/EU</b>	<b>Article 3.1b</b>	EN 55014-1:2021 + A11:2020
		EN 55014-2:2021 + A1:2001 + A2:2008
		EN 55015:2019 + A11:2020
		EN 61547:2009
		EN 61000-3-2:2019 + A1:2021 + A2:2024 (only if $\geq 5W$ )
		EN 61000-3-3:2013 + A1:2019 + A2:2021 (only if $\geq 5W$ )
		EN 301 489-1 V2.2.3
EN 301 489-3 V2.3.2		
<b>Directive RED 2014/35/EU</b>	<b>Article 3.2</b>	EN 300 220-1 V3.1.1
		EN 300 220-2 V3.2.1
<b>Directive RoHS 2015/863/EU</b>		UNE-EN IEC 63000:2018
<b>ErP Directive 2009/125/EC</b>		Regulation 2019/2020
		Regulation 206/2012
		IEC 60879:2019

  
SULION DIGITAL S.A.

Madrid, 25/11/2025

**C. Schuller**  
CEO









**sulion.es**

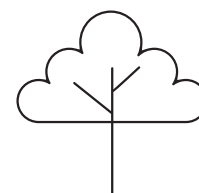

**ES** Elige reparar, no desperdiciar.

Nuestro propósito es generar un impacto positivo en el medio ambiente y en la sociedad. Ofrecemos repuestos fáciles de instalar para evitar devoluciones y reducir residuos. Contacte con nosotros para soluciones responsables y visite [sulion.es](http://sulion.es) para consejos sobre sostenibilidad y eficiencia energética. Juntos creamos los espacios del mañana.

**EN** Choose to repair, not to waste.

Our purpose is to generate a positive impact on the environment and society. We offer easy-to-install spare parts to avoid returns and reduce waste. Contact us for responsible solutions and visit [sulion.es](http://sulion.es) for tips on sustainability and energy efficiency. Together, we create the spaces of tomorrow.

**FR** Choisissez de réparer, pas de gaspiller.

Notre objectif est de générer un impact positif sur l'environnement et la société. Nous proposons des pièces de rechange faciles à installer pour éviter les retours et réduire les déchets. Contactez-nous pour des solutions responsables et visitez [sulion.es](http://sulion.es) pour des conseils sur la durabilité et l'efficacité énergétique. Ensemble, nous créons les espaces de demain.

**PT** Escolha reparar, não desperdiçar.

Nosso propósito é gerar um impacto positivo no meio ambiente e na sociedade. Oferecemos peças de reposição fáceis de instalar para evitar devoluções e reduzir resíduos. Entre em contato conosco para soluções responsáveis e visite [sulion.es](http://sulion.es) para dicas sobre sustentabilidade e eficiência energética. Juntos, criamos os espaços de amanhã.

**DE** Wählen Sie Reparieren statt Wegwerfen.

Unser Ziel ist es, einen positiven Einfluss auf die Umwelt und die Gesellschaft zu haben. Wir bieten einfach zu installierende Ersatzteile an, um Rücksendungen zu vermeiden und Abfall zu reduzieren. Kontaktieren Sie uns für verantwortungsbewusste Lösungen und besuchen Sie [sulion.es](http://sulion.es) für Tipps zu Nachhaltigkeit und Energieeffizienz. Gemeinsam gestalten wir die Räume von morgen.

**IT** Scegli di riparare, non di sprecare.

Il nostro obiettivo è generare un impatto positivo sull'ambiente e sulla società. Offriamo pezzi di ricambio facili da installare per evitare resi e ridurre i rifiuti. Contattaci per soluzioni responsabili e visita [sulion.es](http://sulion.es) per consigli su sostenibilità ed efficienza energetica. Insieme, creiamo gli spazi di domani.

**EL** Επιλέξτε να επισκευάσετε, όχι να σπαταλήσετε.

Σκοπός μας είναι να δημιουργήσουμε θετικό αντίκτυπο στο περιβάλλον και στην κοινωνία. Προσφέρουμε εύκολα στην εγκατάσταση ανταλλακτικά για να αποφύγουμε τις επιστροφές και να μειώσουμε τα απόβλητα. Επικοινωνήστε μαζί μας για υπεύθυνες λύσεις και επισκεφθείτε το [sulion.es](http://sulion.es) για συμβουλές σχετικά με τη βιωσιμότητα και την ενεργειακή απόδοση. Μαζί δημιουργούμε τους χώρους του αύριο.

